

CHAPTER 5

◆◆ Flat Fan Nozzles

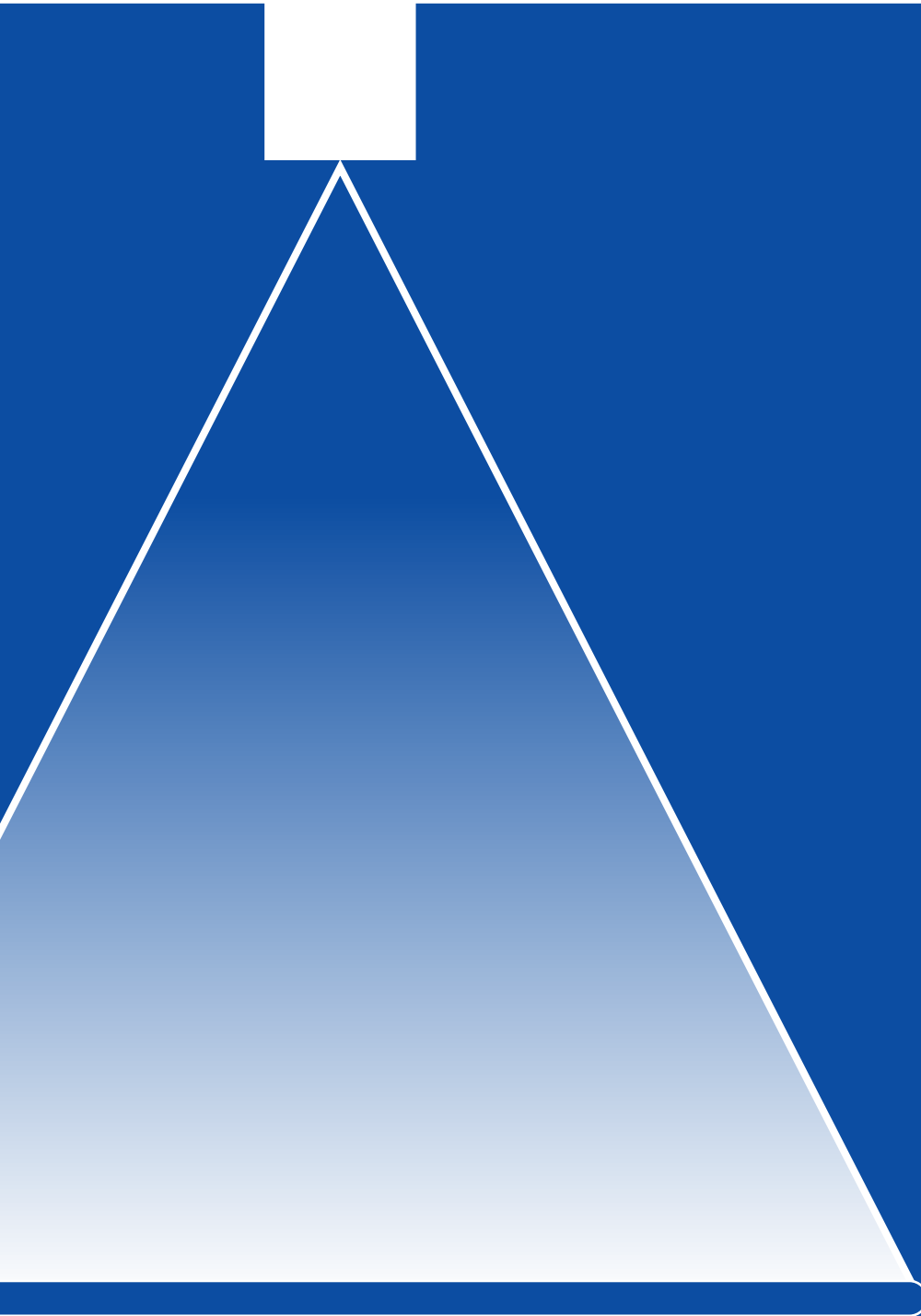

◆ ABOUT US

We Are Here to Help

• Welcome to SPADFLOW

facing the **Challenges** of new industries and emerging markets.

• Spray Technologies

with over **Thousands of Spray Nozzle Types** SPADFLOW has become Iran's leading producer.

• From Design to Installation

with **Skilled** engineers and project managers, SPADFLOW is providing consultancy and support services.

• Knowledge and Experience

as an **Expert** on spray technology, SPADFLOW is at the forefront of production and innovation.





PRODUCT NUMBERS

Everything You Need to Know

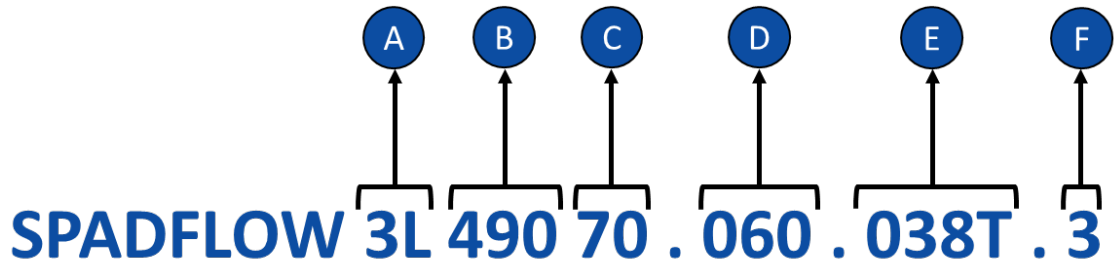

A

Nozzle Type (Spray Pattern)

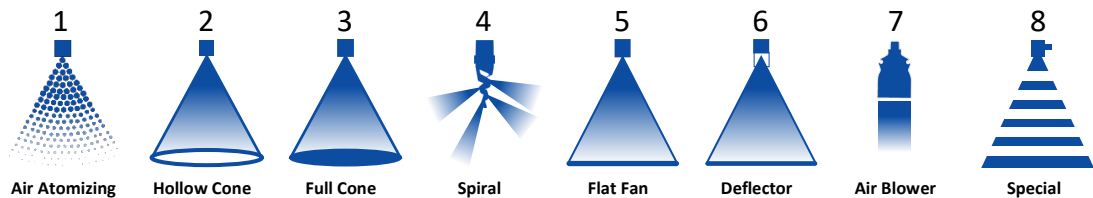

B

Nozzle Series

C

Flow Rate Rank

The flow rate rank is relative and depends on the respective nozzle type. The exact value is mentioned in tables on the product pages.

D

Spray Angle

Theoretical spray angle is mentioned in tables on the product pages. Actual spray angle depends on installation and alignment.

- A = Theoretical Spray Angle
- D = Spray Distance
- C = theoretical Spray Coverage

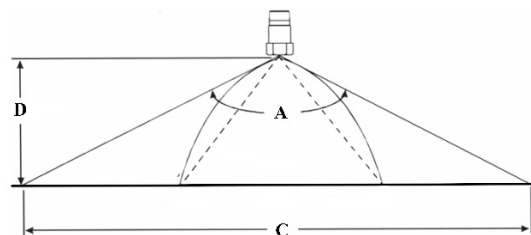



PRODUCT NUMBERS

Everything You Need to Know

E

Connection

1/8" to 4" connections. The exact specification is mentioned in tables on the product pages.

T = BSBT Thread Type Connection

P = BSPP Thread Type Connection

N = NPT Thread Type Connection

R = Retaining Nut

F

Material

Material	Code	Material	Code
Brass	1	Polyvinylchloride	PVC
AISI 304/304L Stainless Steel	2	Polypropylene	PP
AISI 316/316L Stainless Steel	3	Polyamide	PA
AISI 310 Stainless Steel	4	Polyvinylidene fluoride	PVDF
AISI 321 Stainless Steel	5	Polytetrafluorethylene	PTFE
AISI 420 Stainless Steel	6	Polyoxymethylene	POM
Tungsten Carbide	TN	Nitrile Butadiene Rubber	NBR
Phosphor Bronze	CuSn	Poly lactic Acid	PLA
Copper	Cu	Acrylonitrile Butadiene Styrene	ABS
Titanium	TI	Nylon Polyamide	PA6
Aluminum	AL	Polycarbonate	PC

Ø B (Equivalent Bore Diameter)

Applies to elliptical discharge holes of flat fan nozzles. A cylindrical hole with a diameter A has the same surface area as the ellipse.

Ø E (Narrowest Free Cross Section)

Important Characteristics for determining the pre-filtration of a nozzle. Can be less than a due to several swirl ducts.

Conversion Formula: $K \text{ factor} \times \sqrt{P(\text{bar})} = Q (\text{l/min})$

All flow rate data in this catalogue is based on measurements with water,

Spray angle (α)	Code	Connection Size [inch]	Ø B [mm]	Ø E [mm]	Flow rate (Q) [l/min]						
					Pressure (P) [bar]						
					0.5	1.0 <i>K factor</i>	2.0	3.0	5.0	7.0	10.0
45°	3L 490 40 . 045	1/8"	1.25	1.25	0.57	0.76	1.00	1.18	1.44	1.65	1.90
	3L 490 60 . 045	1/4"	2.00	2.00	1.81	2.39	3.15	3.70	4.54	5.20	6.00
	3L 490 70 . 045	3/8"	2.65	2.65	3.22	4.24	5.60	6.59	8.08	9.24	10.66
	3L 490 78 . 045	1/2"	3.45	3.45	5.17	6.82	9.00	10.58	12.98	14.85	17.12
60°	3L 490 40 . 060	1/8"	1.15	1.15	0.57	0.76	1.00	1.18	1.44	1.65	1.90
	3L 490 80 . 060	3/8"	3.70	3.70	5.74	7.58	10.00	11.76	14.43	16.51	19.04
	3L 490 88 . 060	1/2"	4.65	4.65	9.19	12.13	16.00	18.82	23.08	26.41	30.46
	3L 490 96 . 060	3/4"	5.80	5.80	14.36	18.95	25.00	29.40	36.07	41.26	47.59
	3L 491 08 . 060	1"	8.15	8.15	28.72	37.89	50.00	58.80	72.14	82.53	95.18

SPADFLOW spray nozzles are manufactured with the highest precision and undergo permanent quality checks. However, production-related tolerances can affect the spray angle, flow rate, droplet size and droplet distribution.



SPADFLOW 5L 660

Parabolical Distribution Flat-Fan Nozzle

Webpage
+ STP

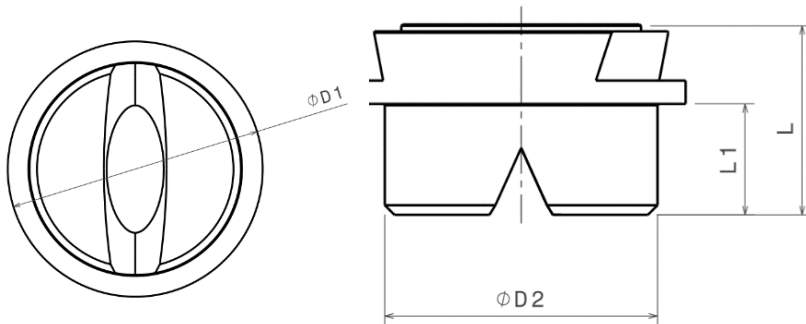

G1	Dimensions [mm]				Weight
	L	L1	D1	D2	
Retaining Nut 3/8"	12.0	7.0	14.8	12.0	13 gr

Material*	Code
Brass	1
S.S.304	2
S.S.316	3

* Different materials are available upon request

Properties:

- One - Piece Construction
- Non-Clogging
- Uniform, Parabolic Liquid Distribution
- Stable Spray Angle

α	Spray coverage @ 250 mm
20°	85 mm
30°	120-130 mm
45°	170-220 mm
60°	260-290 mm
75°	380 mm
90°	420-530 mm
120°	630-900 mm

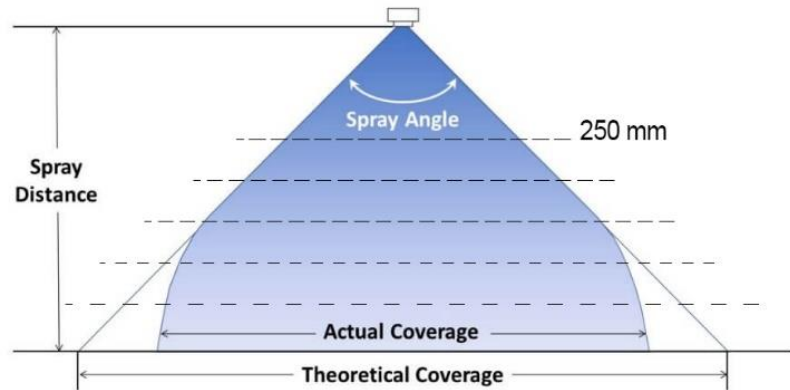

Spray angle (α)	Code	A ϕ [mm]	E ϕ [mm]	Flow rate [l/min]					
				P [bar]					
				0.5	1.0 <i>K factor</i>	2.0	3.0	5.0	10.0
20°	5L 660 30 . 020	0.70	0.60	0.16	0.23	0.32	0.39	0.51	0.72
	5L 660 36 . 020	1.00	0.80	0.31	0.44	0.63	0.77	1.00	1.40
	5L 660 44 . 020	1.35	1.10	0.62	0.88	1.25	1.53	1.98	2.80
	5L 660 48 . 020	1.50	1.20	0.80	1.13	1.60	1.96	2.53	3.58
30°	5L 660 30 . 030	0.60	0.50	0.16	0.23	0.32	0.39	0.51	0.72
	5L 660 36 . 030	1.00	0.70	0.31	0.44	0.63	0.77	1.00	1.40
	5L 660 40 . 030	1.20	0.90	0.50	0.71	1.00	1.23	1.58	2.24
	5L 660 48 . 030	1.50	1.10	0.80	1.13	1.60	1.96	2.53	3.57
	5L 660 56 . 030	2.00	1.50	1.25	1.76	2.50	3.06	3.95	5.59



SPADFLOW 5L 660

Parabolical Distribution Flat-Fan Nozzle

Webpage
+ STP



Spray angle (α)	Code	A Ø [mm]	E Ø [mm]	Flow rate [l/min]					
				P [bar]					
				0.5	1.0 <i>K Factor</i>	2.0	3.0	5.0	10.0
45°	5L 660 30 . 045	0.70	0.50	0.16	0.23	0.32	0.39	0.51	0.72
	5L 660 36 . 045	1.00	0.60	0.31	0.44	0.63	0.77	1.00	1.40
	5L 660 40 . 045	1.20	0.90	0.50	0.71	1.00	1.23	1.58	2.24
	5L 660 48 . 045	1.50	1.10	0.80	1.13	1.60	1.96	2.53	3.58
	5L 660 56 . 045	2.00	1.40	1.25	1.76	2.50	3.06	3.95	5.59
	5L 660 64 . 045	2.50	1.80	2.00	2.83	4.00	4.90	6.33	8.94
60°	5L 660 30 . 060	0.70	0.40	0.16	0.23	0.32	0.39	0.51	0.72
	5L 660 33 . 060	0.90	0.50	0.22	0.32	0.45	0.55	0.71	1.01
	5L 660 36 . 060	1.00	0.60	0.31	0.44	0.63	0.77	1.00	1.40
	5L 660 40 . 060	1.20	0.80	0.50	0.71	1.00	1.23	1.58	2.24
	5L 660 44 . 060	1.35	0.90	0.62	0.88	1.25	1.53	1.98	2.80
	5L 660 48 . 060	1.50	1.00	0.80	1.13	1.60	1.96	2.53	3.58
	5L 660 51 . 060	1.65	1.10	0.95	1.34	1.90	2.33	3.00	4.25
	5L 660 56 . 060	2.00	1.30	1.25	1.77	2.50	3.06	3.95	5.59
	5L 660 60 . 060	2.20	1.50	1.58	2.23	3.15	3.86	4.98	7.04
	5L 660 64 . 060	2.50	1.60	2.00	2.83	4.00	4.90	6.33	8.94
	5L 660 72 . 060	3.00	2.10	3.15	4.46	6.30	7.72	9.96	14.09
5L 660 80 . 060	4.00	2.60	5.00	7.07	10.00	12.25	15.81	22.36	
75°	5L 660 14 . 075	0.20	0.12	-	0.04	0.05	0.06	0.08	0.11
	5L 660 16 . 075	0.20	0.14	-	0.05	0.07	0.08	0.10	0.15
	5L 660 18 . 075	0.20	0.16	-	0.06	0.08	0.10	0.13	0.18
	5L 660 21 . 075	0.50	0.20	-	0.08	0.11	0.14	0.18	0.25
	5L 660 24 . 075	0.50	0.30	-	0.12	0.16	0.20	0.26	0.36
	5L 660 27 . 075	0.60	0.30	0.11	0.16	0.22	0.27	0.35	0.49
90°	5L 660 21 . 090	0.40	0.20	-	0.08	0.11	0.14	0.18	0.25
	5L 660 27 . 090	0.60	0.30	0.11	0.16	0.22	0.27	0.35	0.49
	5L 660 30 . 090	0.70	0.40	0.16	0.23	0.32	0.39	0.51	0.72
	5L 660 33 . 090	0.90	0.50	0.22	0.32	0.45	0.55	0.71	1.01
	5L 660 36 . 090	1.00	0.50	0.31	0.44	0.63	0.77	1.00	1.41
	5L 660 40 . 090	1.20	0.70	0.50	0.71	1.00	1.23	1.58	2.24
	5L 660 44 . 090	1.35	0.80	0.62	0.88	1.25	1.53	1.98	2.80
	5L 660 48 . 090	1.50	0.80	0.80	1.13	1.60	1.96	2.53	3.58
	5L 660 51 . 090	1.65	0.90	0.95	1.34	1.90	2.33	3.00	4.25
	5L 660 56 . 090	2.00	1.10	1.25	1.77	2.50	3.06	3.95	5.59
	5L 660 60 . 090	2.20	1.20	1.58	2.23	3.15	3.86	4.98	7.04
	5L 660 64 . 090	2.50	1.30	2.00	2.83	4.00	4.90	6.33	8.94
	5L 660 67 . 090	2.70	1.40	2.38	3.36	4.75	5.82	7.51	10.62
	5L 660 72 . 090	3.00	1.70	3.15	4.46	6.30	7.72	9.96	14.09
5L 660 80 . 090	4.00	2.40	5.00	7.07	10.00	12.25	15.81	22.36	
120°	5L 660 18 . 120	0.35	0.20	-	0.06	0.08	0.10	0.13	0.18
	5L 660 21 . 120	0.40	0.20	-	0.08	0.11	0.14	0.18	0.25
	5L 660 24 . 120	0.50	0.20	-	0.12	0.16	0.20	0.26	0.36
	5L 660 27 . 120	0.60	0.30	-	0.16	0.22	0.27	0.35	0.49
	5L 660 30 . 120	0.70	0.30	0.16	0.23	0.32	0.39	0.51	0.72
	5L 660 33 . 120	0.90	0.40	0.22	0.32	0.45	0.55	0.71	1.00
	5L 660 36 . 120	1.00	0.40	0.31	0.44	0.63	0.77	1.00	1.41
	5L 660 40 . 120	1.20	0.60	0.50	0.71	1.00	1.23	1.58	2.24
	5L 660 44 . 120	1.35	0.60	0.62	0.88	1.25	1.53	1.98	2.80
	5L 660 48 . 120	1.50	0.60	0.80	1.13	1.60	1.96	2.53	3.58
	5L 660 51 . 120	1.65	0.90	0.95	1.34	1.90	2.33	3.00	4.25
	5L 660 56 . 120	2.00	0.90	1.25	1.77	2.50	3.06	3.95	5.59
	5L 660 60 . 120	2.20	1.10	1.58	2.23	3.15	3.86	4.98	7.04
	5L 660 64 . 120	2.50	1.30	2.00	2.83	4.00	4.90	6.33	8.94
	5L 660 72 . 120	3.00	1.60	3.15	4.46	6.30	7.72	9.96	14.09
	5L 660 80 . 120	4.00	2.00	5.00	7.07	10.00	12.25	15.81	22.36