

## CHAPTER 6

# ◆◆ Deflector Nozzles

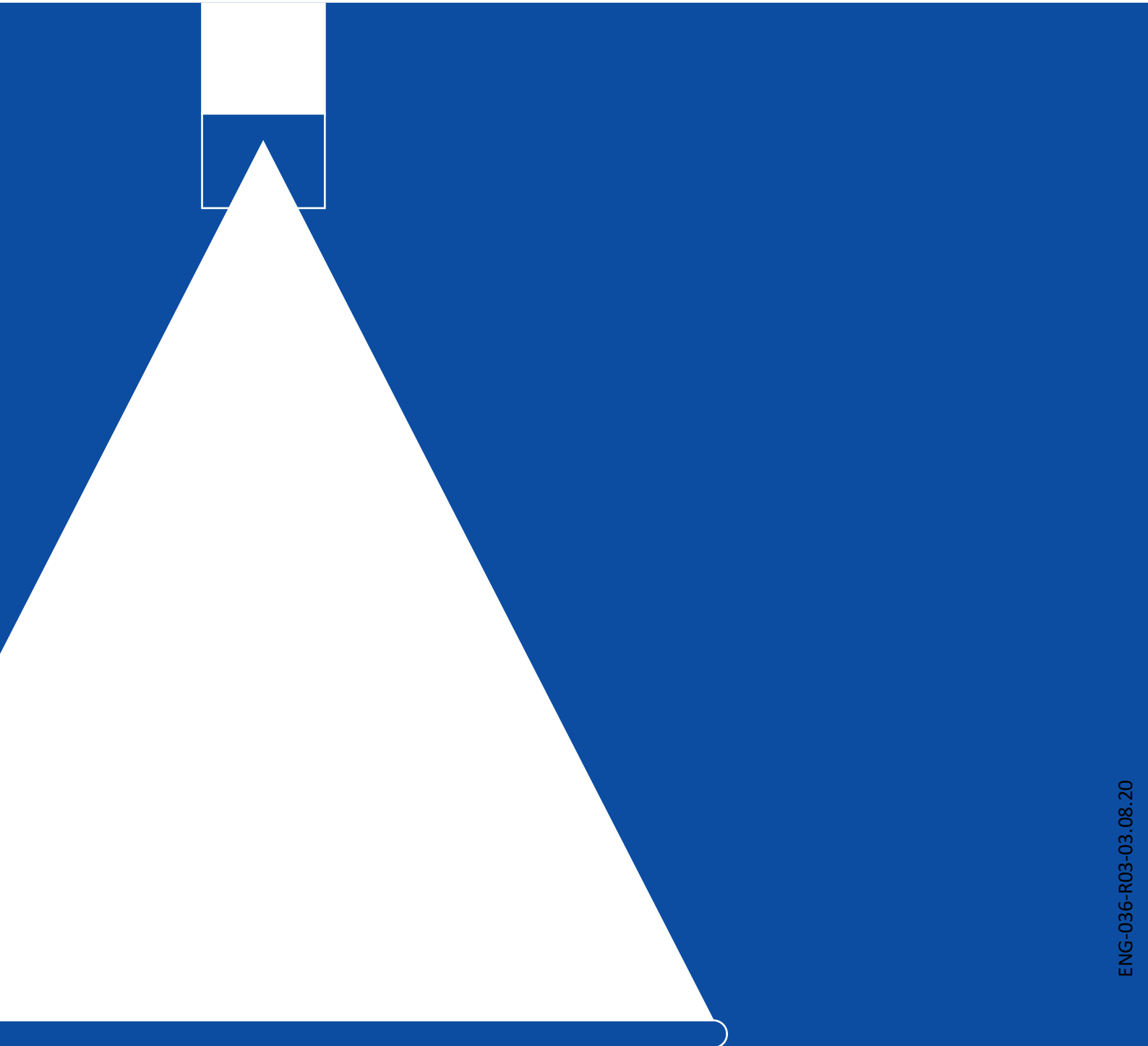

# ◆ ABOUT US

We Are Here to Help

---

## • Welcome to SPADFLOW

facing the **Challenges** of new industries and emerging markets.

## • Spray Technologies

with over **Thousands of Spray Nozzle Types** SPADFLOW has become Iran's leading producer.

## • From Design to Installation

with **Skilled** engineers and project managers, SPADFLOW is providing consultancy and support services.

## • Knowledge and Experience

as an **Expert** on spray technology, SPADFLOW is at the forefront of production and innovation.





# PRODUCT NUMBERS

## Everything You Need to Know

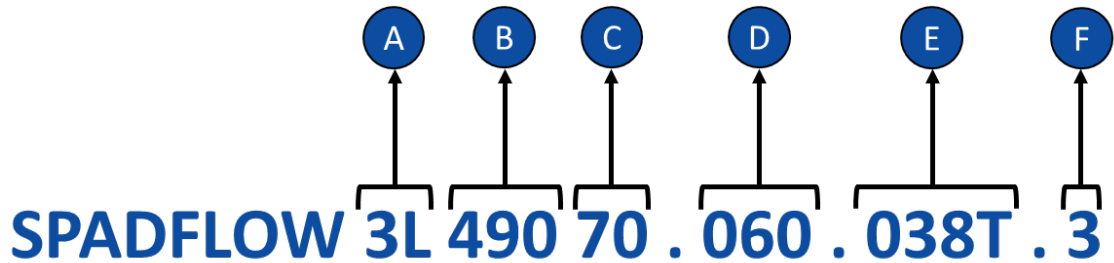

### A

#### Nozzle Type (Spray Pattern)

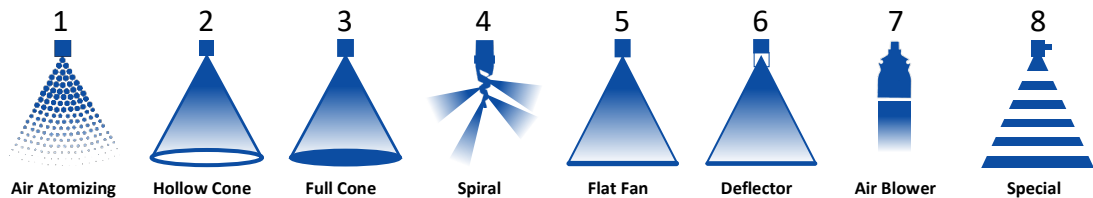

### B

#### Nozzle Series

### C

#### Flow Rate Rank

The flow rate rank is relative and depends on the respective nozzle type. The exact value is mentioned in tables on the product pages.

### D

#### Spray Angle

Theoretical spray angle is mentioned in tables on the product pages. Actual spray angle depends on installation and alignment.

- A = Theoretical Spray Angle
- D = Spray Distance
- C = theoretical Spray Coverage

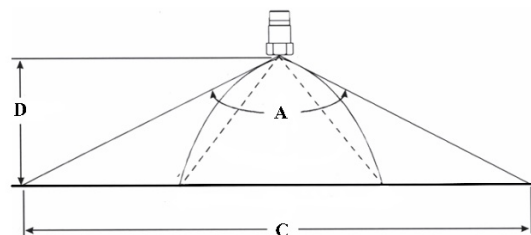

# PRODUCT NUMBERS

## Everything You Need to Know

### E

#### Connection

1/8" to 4" connections. The exact specification is mentioned in tables on the product pages.

T = BSBT Thread Type Connection

P = BSPP Thread Type Connection

N = NPT Thread Type Connection

R = Retaining Nut

### F

#### Material

Material	Code	Material	Code
Brass	1	Polyvinylchloride	PVC
AISI 304/304L Stainless Steel	2	Polypropylene	PP
AISI 316/316L Stainless Steel	3	Polyamide	PA
AISI 310 Stainless Steel	4	Polyvinylidene fluoride	PVDF
AISI 321 Stainless Steel	5	Polytetrafluorethylene	PTFE
AISI 420 Stainless Steel	6	Polyoxymethylene	POM
Tungsten Carbide	TN	Nitrile Butadiene Rubber	NBR
Phosphor Bronze	CuSn	Poly lactic Acid	PLA
Copper	Cu	Acrylonitrile Butadiene Styrene	ABS
Titanium	TI	Nylon Polyamide	PA6
Aluminum	AL	Polycarbonate	PC

#### Ø B (Equivalent Bore Diameter)

Applies to elliptical discharge holes of flat fan nozzles. A cylindrical hole with a diameter A has the same surface area as the ellipse.

#### Ø E (Narrowest Free Cross Section)

Important Characteristics for determining the pre-filtration of a nozzle. Can be less than a due to several swirl ducts.

Conversion Formula:  $K \text{ factor} \times \sqrt{P(\text{bar})} = Q (\text{l/min})$

All flow rate data in this catalogue is based on measurements with water,

Spray angle (α)	Code	Connection Size [inch]	Ø B [mm]	Ø E [mm]	Flow rate (Q) [l/min]						
					Pressure (P) [bar]						
					0.5	1.0 <i>K factor</i>	2.0	3.0	5.0	7.0	10.0
45°	3L 490 40 . 045	1/8"	1.25	1.25	0.57	0.76	1.00	1.18	1.44	1.65	1.90
	3L 490 60 . 045	1/4"	2.00	2.00	1.81	2.39	3.15	3.70	4.54	5.20	6.00
	3L 490 70 . 045	3/8"	2.65	2.65	3.22	4.24	5.60	6.59	8.08	9.24	10.66
	3L 490 78 . 045	1/2"	3.45	3.45	5.17	6.82	9.00	10.58	12.98	14.85	17.12
60°	3L 490 40 . 060	1/8"	1.15	1.15	0.57	0.76	1.00	1.18	1.44	1.65	1.90
	3L 490 80 . 060	3/8"	3.70	3.70	5.74	7.58	10.00	11.76	14.43	16.51	19.04
	3L 490 88 . 060	1/2"	4.65	4.65	9.19	12.13	16.00	18.82	23.08	26.41	30.46
	3L 490 96 . 060	3/4"	5.80	5.80	14.36	18.95	25.00	29.40	36.07	41.26	47.59
	3L 491 08 . 060	1"	8.15	8.15	28.72	37.89	50.00	58.80	72.14	82.53	95.18

SPADFLOW spray nozzles are manufactured with the highest precision and undergo permanent quality checks. However, production-related tolerances can affect the spray angle, flow rate, droplet size and droplet distribution.



# SPADFLOW 6L 686

Powerful Deflector Nozzle

Webpage  
+ STP

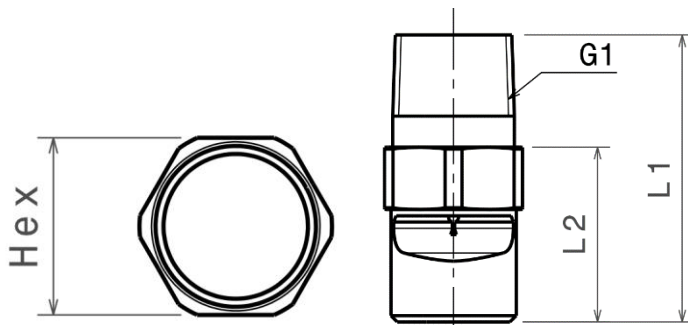

G1	Thread Type			Dimensions [mm]			Weight
	BSPT	BSPP	NPT	L <sub>1</sub>	L <sub>2</sub>	Hex	
1/8"	018T	018P	018N	23.0	6.5	11	17 gr
1/4"	014T	014P	014N	35.0	9.7	14	20 gr
3/8"	038T	038P	038N	38.5	10.1	17	30 gr
1/2"	012T	012P	012N	45.0	13.2	22	40 gr

Material*	Code
Brass	1
S.S.304	2
S.S.316	3

\* Different materials are available upon request

### Properties:

- Wide Flat-Fan Spray
- Sharply Delimited Jet Pattern
- Particularly Clog-Proof

α	Spray coverage
	@ 250 mm
90°	520-530 mm
140°	1360-1370 mm

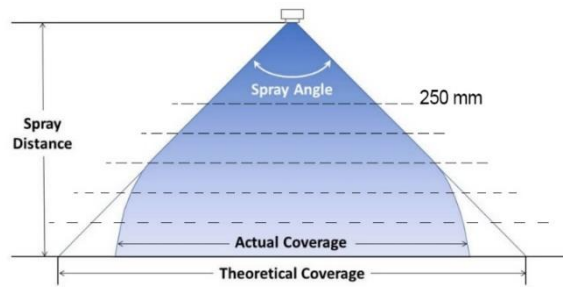

Spray angle (α)	Code	η	Connection [Inch]	B Ø [mm]	Flow rate [l/min]		
					P [bar]		
					1.0 <i>K factor</i>	2.0	5.0
90°	5L 686 36 . 090	75°	1/8"-1/4"	0.80	<b>0.45</b>	0.63	1.00
	5L 686 40 . 090	75°	1/8"-1/4"	1.00	<b>0.71</b>	1.00	1.58
	5L 686 68 . 090	40°	1/4"	2.40	<b>3.54</b>	5.00	7.91
	5L 686 72 . 090	40°	1/8"-1/4"	2.70	<b>4.45</b>	6.30	9.96
	5L 686 80 . 090	40°	1/4"	3.40	<b>7.07</b>	10.00	15.81
	5L 686 88 . 090	40°	1/4"	4.20	<b>11.31</b>	16.00	25.30
	5L 686 92 . 090	40°	3/8"	4.70	<b>14.14</b>	20.00	31.62



# SPADFLOW 6L 686

## Powerful Deflector Nozzle

Webpage  
+ STP



Spray angle (α)	Code	η	Connection [Inch]	B ∅ [mm]	Flow rate [l/min]		
					P [bar]		
					1.0 <i>K factor</i>	2.0	5.0
140°	5L 686 36 . 140	75°	1/8"-1/4"	0.80	<b>0.45</b>	0.63	1.00
	5L 686 40 . 140	75°	1/8"-1/4"	1.00	<b>0.71</b>	1.00	1.58
	5L 686 44 . 140	75°	1/4"	1.20	<b>0.88</b>	1.25	1.98
	5L 686 48 . 140	75°	1/8"1/4"	1.30	<b>1.13</b>	1.60	2.53
	5L 686 52 . 140	75°	1/8"1/4"	1.50	<b>1.41</b>	2.00	3.16
	5L 686 56 . 140	75°	1/8"1/4"	1.70	<b>1.77</b>	2.50	3.59
	5L 686 60 . 140	75°	1/8"1/4"	1.90	<b>2.23</b>	3.15	4.98
	5L 686 64 . 140	75°	1/4"	2.20	<b>2.83</b>	4.00	6.32
	5L 686 68 . 140	75°	1/8"1/4"	2.40	<b>3.54</b>	5.00	7.91
	5L 686 72 . 140	75°	1/8"1/4"	2.70	<b>4.45</b>	6.30	9.96
	5L 686 76 . 140	75°	1/4"	3.00	<b>5.66</b>	8.00	12.65
	5L 686 80 . 140	75°	1/8"1/4"	3.40	<b>7.07</b>	10.00	15.81
	5L 686 82 . 140	75°	1/4"	3.60	<b>7.92</b>	11.20	17.71
	5L 686 84 . 140	75°	1/4"	3.80	<b>8.80</b>	12.50	19.76
	5L 686 86 . 140	75°	1/4"	4.00	<b>9.90</b>	14.00	22.14
	5L 686 88 . 140	75°	1/4"	4.20	<b>11.31</b>	16.00	25.30
	5L 686 90 . 140	75°	1/4"	4.50	<b>12.73</b>	18.00	28.46
	5L 686 92 . 140	75°	3/8"	4.70	<b>14.14</b>	20.00	31.62
5L 686 96 . 140	75°	1/2"	5.30	<b>17.68</b>	25.00	39.53	
5L 686 98 . 140	75°	3/8"-1/2"	5.60	<b>19.80</b>	28.00	44.27	