

CHAPTER 4

◆◆ Spiral Nozzles

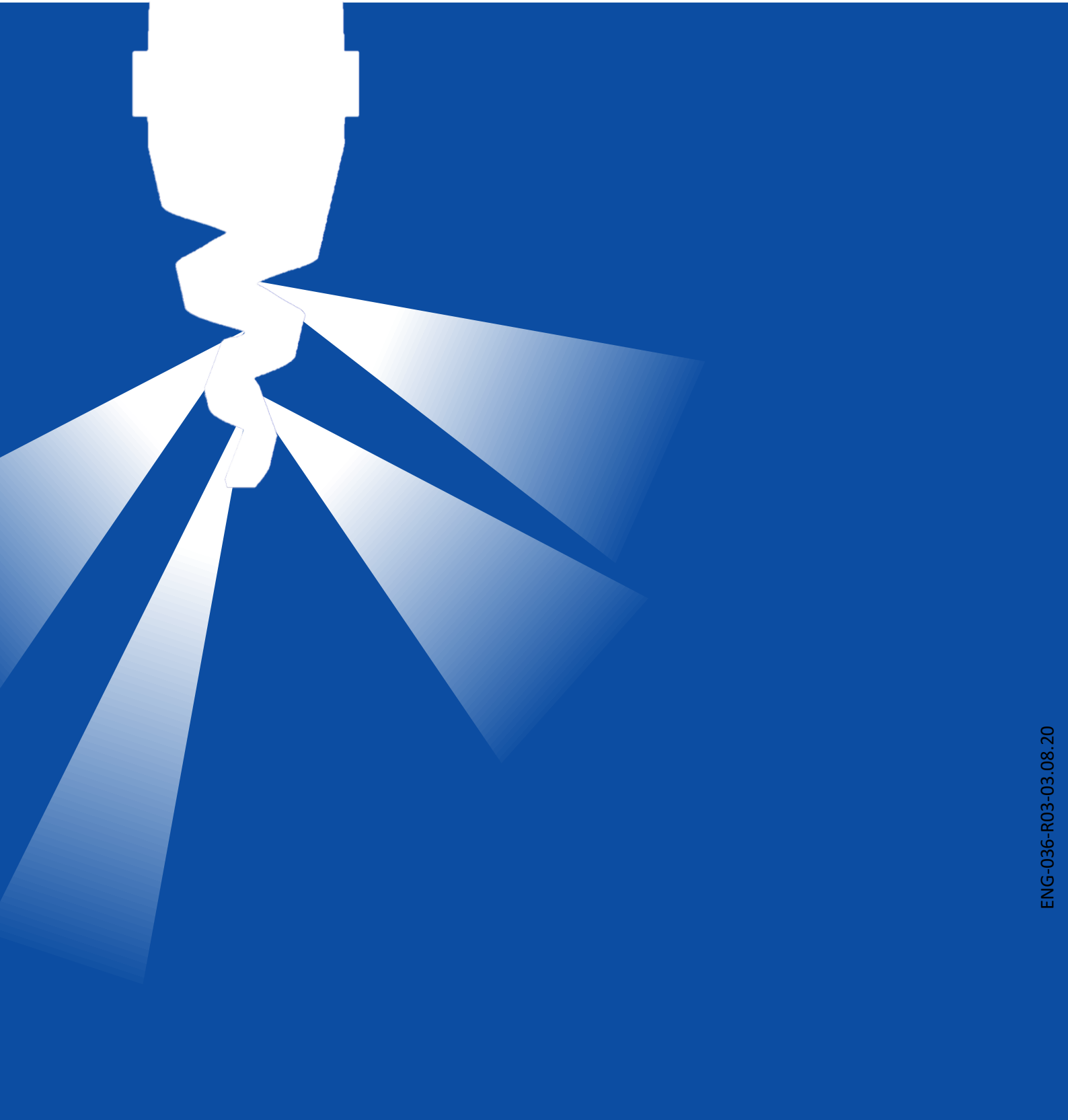

◆ ABOUT US

We Are Here to Help

• Welcome to SPADFLOW

facing the **Challenges** of new industries and emerging markets.

• Spray Technologies

with over **Thousands of Spray Nozzle Types** SPADFLOW has become Iran's leading producer.

• From Design to Installation

with **Skilled** engineers and project managers, SPADFLOW is providing consultancy and support services.

• Knowledge and Experience

as an **Expert** on spray technology, SPADFLOW is at the forefront of production and innovation.





Design



Simulation



Production



Installation



PRODUCT NUMBERS

Everything You Need to Know

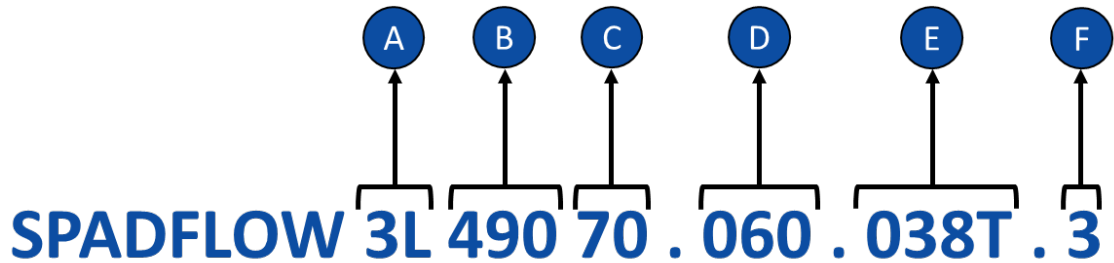

A

Nozzle Type (Spray Pattern)

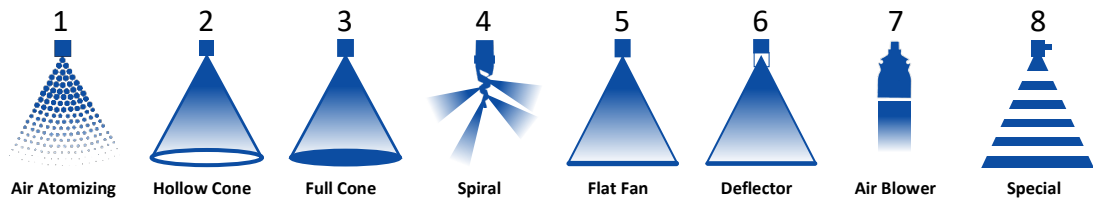

B

Nozzle Series

C

Flow Rate Rank

The flow rate rank is relative and depends on the respective nozzle type. The exact value is mentioned in tables on the product pages.

D

Spray Angle

Theoretical spray angle is mentioned in tables on the product pages. Actual spray angle depends on installation and alignment.

- A = Theoretical Spray Angle
- D = Spray Distance
- C = theoretical Spray Coverage

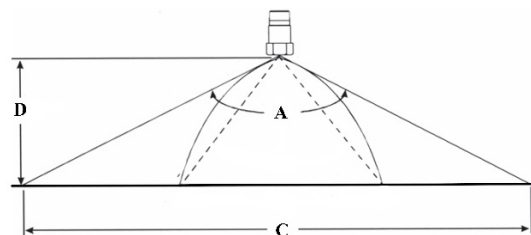

PRODUCT NUMBERS

Everything You Need to Know

E

Connection

1/8" to 4" connections. The exact specification is mentioned in tables on the product pages.

T = BSBT Thread Type Connection

P = BSPP Thread Type Connection

N = NPT Thread Type Connection

R = Retaining Nut

F

Material

Material	Code	Material	Code
Brass	1	Polyvinylchloride	PVC
AISI 304/304L Stainless Steel	2	Polypropylene	PP
AISI 316/316L Stainless Steel	3	Polyamide	PA
AISI 310 Stainless Steel	4	Polyvinylidene fluoride	PVDF
AISI 321 Stainless Steel	5	Polytetrafluorethylene	PTFE
AISI 420 Stainless Steel	6	Polyoxymethylene	POM
Tungsten Carbide	TN	Nitrile Butadiene Rubber	NBR
Phosphor Bronze	CuSn	Polylactic Acid	PLA
Copper	Cu	Acrylonitrile Butadiene Styrene	ABS
Titanium	TI	Nylon Polyamide	PA6
Aluminum	AL	Polycarbonate	PC

Ø B (Equivalent Bore Diameter)

Applies to elliptical discharge holes of flat fan nozzles. A cylindrical hole with a diameter A has the same surface area as the ellipse.

Ø E (Narrowest Free Cross Section)

Important Characteristics for determining the pre-filtration of a nozzle. Can be less than a due to several swirl ducts.

Conversion Formula: $K \text{ factor} \times \sqrt{P(\text{bar})} = Q \text{ (l/min)}$

All flow rate data in this catalogue is based on measurements with water,

Spray angle (α)	Code	Connection Size [inch]	Ø B [mm]	Ø E [mm]	Flow rate (Q) [l/min]						
					Pressure (P) [bar]						
					0.5	1.0	2.0	3.0	5.0	7.0	10.0
45°	3L 490 40 . 045	1/8"	1.25	1.25	0.57	0.76	1.00	1.18	1.44	1.65	1.90
	3L 490 60 . 045	1/4"	2.00	2.00	1.81	2.39	3.15	3.70	4.54	5.20	6.00
	3L 490 70 . 045	3/8"	2.65	2.65	3.22	4.24	5.60	6.59	8.08	9.24	10.66
	3L 490 78 . 045	1/2"	3.45	3.45	5.17	6.82	9.00	10.58	12.98	14.85	17.12
60°	3L 490 40 . 060	1/8"	1.15	1.15	0.57	0.76	1.00	1.18	1.44	1.65	1.90
	3L 490 80 . 060	3/8"	3.70	3.70	5.74	7.58	10.00	11.76	14.43	16.51	19.04
	3L 490 88 . 060	1/2"	4.65	4.65	9.19	12.13	16.00	18.82	23.08	26.41	30.46
	3L 490 96 . 060	3/4"	5.80	5.80	14.36	18.95	25.00	29.40	36.07	41.26	47.59
	3L 491 08 . 060	1"	8.15	8.15	28.72	37.89	50.00	58.80	72.14	82.53	95.18

SPADFLOW spray nozzles are manufactured with the highest precision and undergo permanent quality checks. However, production-related tolerances can affect the spray angle, flow rate, droplet size and droplet distribution.

Spiral Nozzles

Selection Guide



Nozzle Series	Flow Capacity	Operating Pressures	Spray Angle	Application	Page
 4B TF	High Flow Up to 10000 liters per Minute	Standard Pressure Up to 20 bar	Wide Spray Angle 60° - 90° - 120° - 150° - 170°	Quenching Scrubbing Fire Protection Humidification Dust Control Cooling Aeration	49 - 51

SPADFLOW 4B TF

Clog-Resistance Cone Nozzle

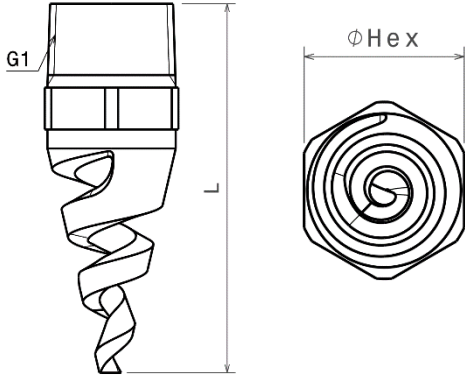

G1	Connection Type			Dimensions [mm]			Weight
	BSPT	BSPP	NPT	L ₁	L ₂	Hex	
1/8"	018T	018P	018N	42.9	42.9	14.3	28 gr
1/8"	01/8T	018P	018N	42.9	55.6	14.3	28 gr
1/4"	01/4T	014P	014N	47.6	47.6	14.3	35 gr
1/4"	01/4T	014P	014N	47.6	60.3	14.3	35 gr
3/8"	03/8T	018P	038N	47.6	60.5	17.5	46 gr
1/2"	01/2T	012P	012N	63.5	77.7	22.2	85 gr
3/4"	03/4T	034P	034N	69.9	88.9	28.6	156 gr
1"	100T	100P	100N	92.1	111	34.9	241 gr
1 1/2"	112T	112P	112N	111	137	50.8	624 gr
1 1/2"	112T	112P	112N	111	143	50.8	624 gr
2"	200T	200P	200N	143	175	63.5	1300 gr
2"	200T	200P	200N	176	178	63.5	1530 gr
3"	300T	300P	300N	219	235	88.9	3230 gr
4"	400T	400P	400N	257	-	114	4790 gr

L1 refer to 60°, 90°, and 120°

L2 refer to 150° and 170°

Material*	Code
Brass	1
S.S.304	2
S.S.316	3

* Different materials are available upon request

α	Spray coverage @ 250 mm
60°	280
90°	500
120°	850
150°	1850
170°	5500

Properties:

- One-Piece Construction
- No Internal Parts
- Passes Particles Equal to Orifice Size
- Large Free Cross Section
- Fine Atomization
- Clog-Resistant Performance
- High Discharge Velocity
- High Energy Efficiency

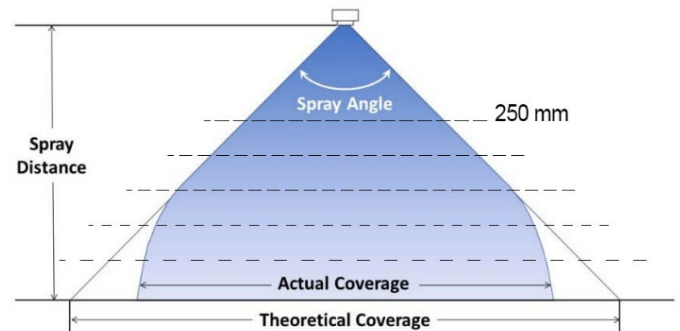



SPADFLOW 4B TF

Clog-Resistance Cone Nozzle



Spray angle (α)	Code	Connection [inch]	B Ø [mm]	E Ø [mm]	Flow rate [l/min]							
					P [bar]							
					0.5	0.7	1.0 <i>K</i> <i>factor</i>	2.0	3.0	5.0	10.0	20.0
60°	4B TF 06 . 060	1/8"-1/4"-3/8"	2.38	2.38	2.26	2.67	3.19	4.5	5.5	7.1	10.1	14.3
	4B TF 08 . 060	1/8"-1/4"-3/8"	3.18	3.18	4.19	4.96	5.93	8.4	10.3	13.2	18.7	26.5
	4B TF 10 . 060	1/4"-3/8"	3.97	3.18	6.45	7.63	9.12	12.9	15.8	20.4	28.8	40.8
	4B TF 12 . 060	3/8"	4.76	3.18	9.67	11.4	13.7	19.3	23.7	30.6	43.2	61.1
	4B TF 14 . 060	3/8"	5.56	3.18	13.1	15.4	18.5	26.1	32.0	41.3	58.4	82.6
	4B TF 16 . 060	3/8"	6.35	3.18	17.1	20.2	24.2	34.2	41.8	54.0	76.4	108
	4B TF 20 . 060	3/8"	7.94	3.18	26.6	31.5	37.6	53.2	65.1	84.1	119	168
	4B TF 24 . 060	1/2"	9.53	4.76	38.8	46.0	54.9	77.7	95.1	123	174	246
	4B TF 28 . 060	1/2"	11.1	4.76	53.2	62.9	75.2	106	130	168	238	336
	4B TF 32 . 060	3/4"	12.7	4.76	67.7	80.1	95.7	135	166	214	303	428
	4B TF 40 . 060	1"	15.9	6.35	108	128	153	216	264	341	483	683
	4B TF 48 . 060	1"	19.1	6.35	153	181	216	306	375	484	685	968
	4B TF 56 . 060	1 1/2"	22.2	7.94	208	246	294	416	509	657	930	1320
	4B TF 64 . 060	1 1/2"	25.4	7.94	272	322	385	545	667	861	1220	1720
	4B TF 72 . 060	1 1/2"	28.6	7.94	309	366	438	619	758	978	1380	1960
	4B TF 88 . 060	2"	34.9	11.1	451	534	638	902	1110	1430	2020	2850
4B TF 96 . 060	2"	38.1	11.1	570	674	806	1140	1400	1800	2550	3600	
4B TF 112 . 060	3"	44.5	14.3	825	976	1170	1650	2020	2610	3690	5220	
4B TF 128 . 060	3"	50.8	14.3	1090	1290	1550	2190	2680	3460	4891	6920	
4B TF 160 . 060	4"	63.5	15.9	1690	2000	2390	3380	4140	5350	7570	10700	
90°	4B TF 06 . 090	1/8"-1/4"-3/8"	2.38	2.38	2.26	2.67	3.19	4.5	5.5	7.1	10.1	14.3
	4B TF 08 . 090	1/8"-1/4"-3/8"	3.18	3.18	4.19	4.96	5.93	8.4	10.3	13.2	18.7	26.5
	4B TF 10 . 090	1/4"-3/8"	3.97	3.18	6.45	7.63	9.12	12.9	15.8	20.4	28.8	40.8
	4B TF 12 . 090	3/8"	4.76	3.18	9.67	11.4	13.7	19.3	23.7	30.6	43.2	61.1
	4B TF 14 . 090	3/8"	5.56	3.18	13.1	15.4	18.5	26.1	32.0	41.3	58.4	82.6
	4B TF 16 . 090	3/8"	6.35	3.18	17.1	20.2	24.2	34.2	41.8	54.0	76.4	108
	4B TF 20 . 090	3/8"	7.94	3.18	26.6	31.5	37.6	53.2	65.1	84.1	119	168
	4B TF 24 . 090	1/2"	9.53	4.76	38.8	46.0	54.9	77.7	95.1	123	174	246
	4B TF 28 . 090	1/2"	11.1	4.76	53.2	62.9	75.2	106	130	168	238	336
	4B TF 32 . 090	3/4"	12.7	4.76	67.7	80.1	95.7	135	166	214	303	428
	4B TF 40 . 090	1"	15.9	6.35	108	128	153	216	264	341	483	683
	4B TF 48 . 090	1"	19.1	6.35	153	181	216	306	375	484	685	968
	4B TF 56 . 090	1 1/2"	22.2	7.94	208	246	294	416	509	657	930	1320
	4B TF 64 . 090	1 1/2"	25.4	7.94	272	322	385	545	667	861	1220	1720
	4B TF 72 . 090	1 1/2"	28.6	7.94	309	366	438	619	758	978	1380	1960
	4B TF 88 . 090	2"	34.9	11.1	451	534	638	902	1110	1430	2020	2850
4B TF 96 . 090	2"	38.1	11.1	570	674	806	1140	1400	1800	2550	3600	
4B TF 112 . 090	3"	44.5	14.3	825	976	1170	1650	2020	2610	3690	5220	
4B TF 128 . 090	3"	50.8	14.3	1090	1290	1550	2190	2680	3460	4891	6920	
4B TF 160 . 090	4"	63.5	15.9	1690	2000	2390	3380	4140	5350	7570	10700	
120°	4B TF 06 . 120	1/8"-1/4"-3/8"	2.38	2.38	2.26	2.67	3.19	4.5	5.5	7.1	10.1	14.3
	4B TF 08 . 120	1/8"-1/4"-3/8"	3.18	3.18	4.19	4.96	5.93	8.4	10.3	13.2	18.7	26.5
	4B TF 10 . 120	1/4"-3/8"	3.97	3.18	6.45	7.63	9.12	12.9	15.8	20.4	28.8	40.8
	4B TF 12 . 120	3/8"	4.76	3.18	9.67	11.4	13.7	19.3	23.7	30.6	43.2	61.1
	4B TF 14 . 120	3/8"	5.56	3.18	13.1	15.4	18.5	26.1	32.0	41.3	58.4	82.6
	4B TF 16 . 120	3/8"	6.35	3.18	17.1	20.2	24.2	34.2	41.8	54.0	76.4	108
	4B TF 20 . 120	3/8"	7.94	3.18	26.6	31.5	37.6	53.2	65.1	84.1	119	168
	4B TF 24 . 120	1/2"	9.53	4.76	38.8	46.0	54.9	77.7	95.1	123	174	246
	4B TF 28 . 120	1/2"	11.1	4.76	53.2	62.9	75.2	106	130	168	238	336
	4B TF 32 . 120	3/4"	12.7	4.76	67.7	80.1	95.7	135	166	214	303	428
	4B TF 40 . 120	1"	15.9	6.35	108	128	153	216	264	341	483	683
	4B TF 48 . 120	1"	19.1	6.35	153	181	216	306	375	484	685	968
	4B TF 56 . 120	1 1/2"	22.2	7.94	208	246	294	416	509	657	930	1320
	4B TF 64 . 120	1 1/2"	25.4	7.94	272	322	385	545	667	861	1220	1720
	4B TF 72 . 120	1 1/2"	28.6	7.94	309	366	438	619	758	978	1380	1960
	4B TF 88 . 120	2"	34.9	11.1	451	534	638	902	1110	1430	2020	2850
4B TF 96 . 120	2"	38.1	11.1	570	674	806	1140	1400	1800	2550	3600	
4B TF 112 . 120	3"	44.5	14.3	825	976	1170	1650	2020	2610	3690	5220	
4B TF 128 . 120	3"	50.8	14.3	1090	1290	1550	2190	2680	3460	4891	6920	
4B TF 160 . 120	4"	63.5	15.9	1690	2000	2390	3380	4140	5350	7570	10700	

SPADFLOW 4B TF

Clog-Resistance Cone Nozzle



Spray angle (α)	Code	Connection [inch]	B Ø [mm]	E Ø [mm]	Flow rate [l/min]							
					P [bar]							
					0.5	0.7	1.0 <i>K factor</i>	2.0	3.0	5.0	10.0	20.0
150°	4B TF 06 . 150	1/8"-1/4"	2.38	2.38	2.26	2.67	3.19	4.5	5.5	7.1	10.1	14.3
	4B TF 08 . 150	1/8"-1/4"	3.18	3.18	4.19	4.96	5.93	8.4	10.3	13.2	18.7	26.5
	4B TF 10 . 150	1/4"	3.97	3.18	6.45	7.63	9.12	12.9	15.8	20.4	28.8	40.8
	4B TF 12 . 150	3/8"	4.76	3.18	9.67	11.4	13.7	19.3	23.7	30.6	43.2	61.1
	4B TF 14 . 150	3/8"	5.56	3.18	13.1	15.4	18.5	26.1	32.0	41.3	58.4	82.6
	4B TF 16 . 150	3/8"	6.35	3.18	17.1	20.2	24.2	34.2	41.8	54.0	76.4	108
	4B TF 20 . 150	3/8"	7.94	3.18	26.6	31.5	37.6	53.2	65.1	84.1	119	168
	4B TF 24 . 150	1/2"	9.53	4.76	38.8	46.0	54.9	77.7	95.1	123	174	246
	4B TF 28 . 150	1/2"	11.1	4.76	53.2	62.9	75.2	106	130	168	238	336
	4B TF 32 . 150	3/4"	12.7	4.76	67.7	80.1	95.7	135	166	214	303	428
	4B TF 40 . 150	1"	15.9	6.35	108	128	153	216	264	341	483	683
	4B TF 48 . 150	1"	19.1	6.35	153	181	216	306	375	484	685	968
	4B TF 56 . 150	1 1/2"	22.2	7.94	208	246	294	416	509	657	930	1320
	4B TF 64 . 150	1 1/2"	25.4	7.94	272	322	385	545	667	861	1220	1720
	4B TF 72 . 150	1 1/2"	28.6	7.94	309	366	438	619	758	978	1380	1960
	4B TF 88 . 150	2"	34.9	11.1	451	534	638	902	1110	1430	2020	2850
4B TF 96 . 150	2"	38.1	11.1	570	674	806	1140	1400	1800	2550	3600	
4B TF 112 . 150	3"	44.5	14.3	825	976	1170	1650	2020	2610	3690	5220	
4B TF 128 . 150	3"	50.8	14.3	1090	1290	1550	2190	2680	3460	4891	6920	
170°	4B TF 06 . 170	1/8"-1/4"	2.38	2.38	2.26	2.67	3.19	4.5	5.5	7.1	10.1	14.3
	4B TF 08 . 170	1/8"-1/4"	3.18	3.18	4.19	4.96	5.93	8.4	10.3	13.2	18.7	26.5
	4B TF 10 . 170	1/4"	3.97	3.18	6.45	7.63	9.12	12.9	15.8	20.4	28.8	40.8
	4B TF 12 . 170	3/8"	4.76	3.18	9.67	11.4	13.7	19.3	23.7	30.6	43.2	61.1
	4B TF 14 . 170	3/8"	5.56	3.18	13.1	15.4	18.5	26.1	32.0	41.3	58.4	82.6
	4B TF 16 . 170	3/8"	6.35	3.18	17.1	20.2	24.2	34.2	41.8	54.0	76.4	108
	4B TF 20 . 170	3/8"	7.94	3.18	26.6	31.5	37.6	53.2	65.1	84.1	119	168
	4B TF 24 . 170	1/2"	9.53	4.76	38.8	46.0	54.9	77.7	95.1	123	174	246
	4B TF 28 . 170	1/2"	11.1	4.76	53.2	62.9	75.2	106	130	168	238	336
	4B TF 32 . 170	3/4"	12.7	4.76	67.7	80.1	95.7	135	166	214	303	428
	4B TF 40 . 170	1"	15.9	6.35	108	128	153	216	264	341	483	683
	4B TF 48 . 170	1"	19.1	6.35	153	181	216	306	375	484	685	968
	4B TF 56 . 170	1 1/2"	22.2	7.94	208	246	294	416	509	657	930	1320
	4B TF 64 . 170	1 1/2"	25.4	7.94	272	322	385	545	667	861	1220	1720
	4B TF 72 . 170	1 1/2"	28.6	7.94	309	366	438	619	758	978	1380	1960
	4B TF 88 . 170	2"	34.9	11.1	451	534	638	902	1110	1430	2020	2850
4B TF 96 . 170	2"	38.1	11.1	570	674	806	1140	1400	1800	2550	3600	
4B TF 112 . 170	3"	44.5	14.3	825	976	1170	1650	2020	2610	3690	5220	
4B TF 128 . 170	3"	50.8	14.3	1090	1290	1550	2190	2680	3460	4891	6920	