

Axial Flow Full-Cone Spray Nozzles

Spadflow Series 3L 405



3L 405

High Flow Full-Cone Nozzle

Applications:

- Cleaning and washing
- Surface spraying
- Spraying over packings
- Chemical process engineering
- Cooling of gaseous fluids and solids
- Water treatment

Properties:

- Very uniform spray pattern

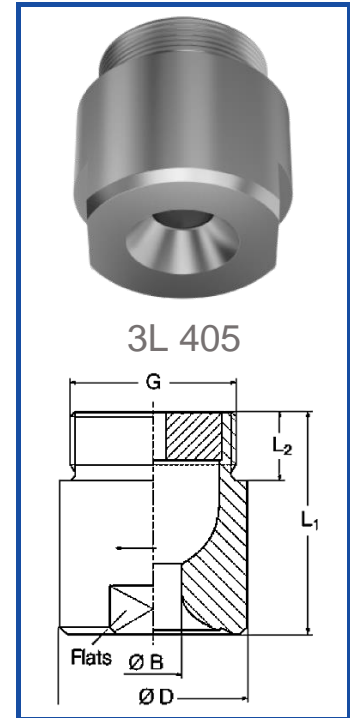

Conn. code	Dimensions [mm]					Weight
	G	L ₁	L ₂	D	Hex/Flats	
114	1 1/4 BSPT	18.0	6.5	10.0	11	13 g
112	1 1/2 BSPP	42.0	15.0	32.0	27	190 g
200	2 BSPP	56.0	17.0	40.0	36	350 g

Material*	Code
Brass	1
S.S.304	2
S.S.316	3

α	C [mm] (range) @ H=500 mm
60°	560-580
90°	780-850
120°	1450-1500

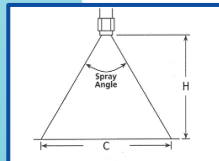

For higher lengths: $C_2 = \frac{C \times H_2}{500}$

Spray angle (α)	Code	Connection** [inch]	B Ø [mm]	E Ø [mm]	Flow rate [l/min]					
					P [bar]					
					0.3	0.5	1.0 <i>K factor</i>	2.0	3.0	5.0
60°	3L 405 20 . 060	1 1/4"	11.20	5.80	47	57	76	100	118	144
	3L 405 28 . 060	1 1/2"	14.30	7.00	75	92	121	160	188	231
	3L 405 32 . 060	2"	16.40	7.50	94	115	152	200	235	289
	3L 405 36 . 060	2"	18.40	8.50	117	144	189	250	294	361
	3L 405 40 . 060	2"	20.00	7.00	147	181	239	315	370	454
90°	3L 405 20 . 090	1 1/4"	12.00	5.00	47	57	76	100	118	144
	3L 405 28 . 090	1 1/2"	15.20	6.20	75	92	121	160	188	231
	3L 405 32 . 090	2"	17.20	7.70	94	115	152	200	235	289
	3L 405 36 . 090	2"	19.50	8.70	117	144	189	250	294	361
	3L 405 40 . 090	2"	22.00	9.50	147	181	239	315	370	454
120°	3L 405 20 . 120	1 1/4"	12.70	5.00	47	57	76	100	118	144
	3L 405 28 . 120	1 1/2"	16.00	6.60	75	92	121	160	188	231
	3L 405 32 . 120	2"	17.80	7.90	94	115	152	200	235	289
	3L 405 36 . 120	2"	20.10	8.80	117	144	189	250	294	361
	3L 405 40 . 120	2"	22.40	9.10	147	181	239	315	370	454

* Different materials are available upon request

B = bore diameter E = narrowest free cross section

** Different connection sizes are available upon request

Order No.: **CODE . CONNETION . MATERIAL**

Example.: 3L 405 . 20 . 060 . 114 . 2

Type 3L 405 with mentioned Q(lpm)@P(bar), Spray angle: 60°, 1 1/4", S.S.316